

Data Sheet



Article number: 071061400235030

Description: Cardan drive shaft 0.106.140.002
S=235 X=30 Bore with keyway

Measures

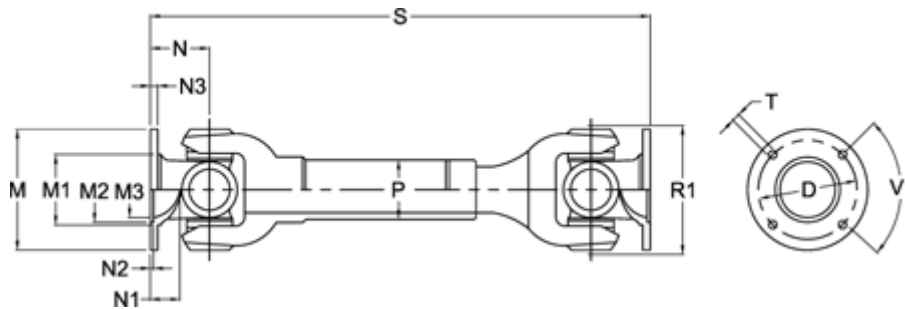

D	= 52 +-0,1	N1	= 12.5	T	= 6 B12
Extension X	= 30	N2	= 1,7 +0,3	V1 degrees	= 90
Flange diameter M	= 65	N3	= 4		
M1	= 38	Number og Flangeholes	= 4		
M2	= 35	P	= 32x1,5		
M3	= 30	R1	= 60		
Max. Bending Angle degrees	= 30	S min	= 235		
N	= 32	Spline dim. DIN 5480	= 25x1,5x15		